

MK08 Bluetooth Module (MK08A、MK08B)

Datasheet

Contents

1. Product Instruction	1
1.1 Model Classification	1
1.2 Key Features	2
1.3 Applications	3
1.4 Product Specifications	4
2. Circuit Design	6
2.1 Block Diagram	6
2.2 Reference Circuitry	6
2.2.1 Normal Voltage Mode	6
2.2.2 High Voltage Mode	7
2.2.3 USB Voltage Mode	7
3. Mechanical specifications	8
3.1 Module Mechanical Dimensions	8
3.2 Recommended PCB land pads	9
4. Pin Assignment	10
5. Mounting Suggestion	13
6. Qualification and approvals	15
6.1 United States (FCC)	15
6.1.1 Labeling and user information requirements	15
6.1.2 RF exposure	15
6.2 Canada (ISED)	16
6.2.1 Labeling and user information requirements	16
6.2.2 RF exposure	17
6.3 European Union regulatory compliance	17
6.3.1 Radio Equipment Directive (RED) 2014/53/EU	17
6.3.2 Labeling and user information requirements	17
6.4 Japan (MIC)	17
6.5 Australia / New Zealand (RCM)	18

7 Cautions	19
7.1 Reflow Soldering	19
7.2 Usage Condition Notes	20
7.3 Storage Notes	21
Revision History	21

1. Product Instruction

MK08 series is a powerful, highly flexible, ultra low power **Bluetooth® 5.0** module based on world-leading **Nordic® Semiconductor nRF52840 SoC** solution, which has a 32bit Arm® Cortex™-M4 CPU with floating point unit running at 64MHz. **MK08** series has NFC-A Tag for use in simplified pairing and payment solutions.

MK08 series brings out all nRF52840 hardware features and capabilities including USB access, up to +8 dBm transmit power up to 5.5V supply considerations, and NFC tag (type 2 / 4) implementation. Complete regulatory certifications enable faster time to market and reduced development risk completes MOKO SMART's simplification of your next Bluetooth design!

MK08 supports a wide range of wireless protocols. It supports BLE® (Bluetooth Low Energy), long distance and 2 Mbps, and also supports Bluetooth mesh, 802.15.4, thread, Zigbee, proprietary 2.4 GHz protocol and NFC-A.

1.1 Model Classification

There are two models of **MK08** series Bluetooth module - **MK08A** and **MK08B**. The two models both have a small size of 21 x 13.8 x 2.3mm with all 46 GPIOs of nRF52840QIAA (7x7mm aQFNTM73 package).

The difference between MK08A and MK08B is the antenna design.

MK08A integrates a high-performance PCB antenna.

MK08B uses a u.FL connector and requires an external 2.4Ghz antenna.

MOKO development team can assist you in selecting high-performance antennas that suit your needs.

1.2 Key Features

- Bluetooth® 5
 - 2Mbps
 - CSA#2
 - Advertising Extensions
 - Long Range
- IEEE 802.15.4 radio support
 - Thread
 - Zigbee
- Supported data rates
 - Bluetooth®: 2 Mbps, 1 Mbps, 500 kbps, and 125 kbps
 - IEEE 802.15.4-2006: 250 kbps
 - Proprietary 2.4 GHz: 2 Mbps, 1 Mbps
- Wide supply voltage range: 1.7 V to 5.5V
- 1MB Flash and 256kB RAM
- Full set of digital interfaces including: SPI, TWI, UART, PDM, PWM, QDEC
- 12-bit/200ksps ADC
- 128-bit AES ECB/CCM/AAR co-processor
- Individual power management for all peripherals
- On-chip DC/DC buck converter
- Dimension: 21.0 x 13.8 x 2.3mm (with shield)
- 46 GPIOs

1.3 Applications

- **Internet of things (IoT)**
 - Smart home sensors and controllers
 - Industrial IoT sensors and controllers
- **Advanced wearables**
 - Health/fitness sensor and monitor devices
 - Wireless payment enabled devices
- **Advanced computer peripherals and I/O devices**
 - Mouse
 - Keyboard
 - Multi-touch trackpad
- **Interactive entertainment devices**
 - Remote controls
 - Gaming controllers

1.4 Product Specifications

Detail	Description
Bluetooth	
Feature	Bluetooth® Low Energy Bluetooth® Mesh 1M LE PHY 2M LE PHY Coded LE PHY (Long Range) Advertising Extensions CSA #2
Security	AES-128; NIST SP800-90A and SP800-90B; HMAC; SRP; RSA
LE connections	Concurrent central, observer, peripheral, and broadcaster roles with up to twenty concurrent connections along with one observer and one broadcaster
Radio	
Frequency	2360MHz - 2500MHz
Modulations	GFSK at 1 Mbps, 2 Mbps 250kbps (IEEE 802.15.4-2006) and Long range (125kbps and 500kbps) data rates
Transmit power	+8 dBm maximum Configurable down to -40dBm
Receiver sensitivity	-103 dBm sensitivity in 125 kbps Bluetooth® LE mode -99 dBm sensitivity in 500 kbps Bluetooth® LE mode -95 dBm sensitivity in 1 Mbps Bluetooth® LE mode -92 dBm sensitivity in 2 Mbps Bluetooth® LE mode -93 dBm sensitivity in 1 Mbps nRF mode -89 dBm sensitivity in 2 Mbps nRF mode -100 dBm sensitivity in IEEE 802.15.4 mode
Antenna	MK08A - PCB trace antenna MK08B - External 2.4Ghz antenna
Current consumption	
TX only (DCDC enabled, 3V) @ +8dBm / +4dBm / 0dBm / -4dBm/-20dBm/-40dBm	14.8mA / 9.6mA / 4.8mA / 3.1mA / 2.7mA / 2.3mA
TX only @ +8dBm / +4dBm / 0dBm / -4dBm / -20dBm / -40dBm	32.7mA / 21.4mA / 10.6mA / 8.1mA / 5.6mA / 4.6mA
RX only (DCDC enabled, 3V) @1Msps / 1Msps BLE	4.6mA
RX only @ 1Msps / 1Mbps BLE	9.9mA
RX only (DCDC enabled, 3V) @2Msps / 2Msps BLE	5.2mA
RX only @ 2Msps / 2Mbps BLE	11.1mA
System OFF mode (3V)	0.4uA
System OFF mode with full 256 kB RAM retention (3V)	1.86uA
System ON mode, no RAM retention, wake on RTC (3V)	1.5uA

MK08 Bluetooth Module

Datasheet

Detail	Description
Mechanical design	
Dimensions	Length: 21mm±0.2mm Width: 13.8mm±0.2mm Height: 2.3mm+0.1mm/-0.15mm
Package	34 diameters of Half-holes + 22 LGA pads
PCB material	FR-4
Impedance	50Ω
Hardware	
CPU	ARM® Cortex®-M4 32-bit processor with FPU, 64 MHz
Memory	1MB flash, 256kB RAM
Interfaces	4x SPI master/3x SPI slave with EasyDMA 2x I ² C compatible two-wire master/slave 2x UART (CTS/RTS) with EasyDMA 3x real-time counter (RTC) 5x 32-bit timer with counter mode 4x 4 channel pulse width modulator (PWM) unit with EasyDMA 46 GPIOs 8x 12bit, 200ksps ADC Audio peripherals – I ² S, digital microphone interface (PDM) USB 2.0 full speed (12 Mbps) controller
Power supply	1.7V to 5.5V
Operating temperature range	-40 to 85 °C
Clock control	32.768 kHz +/-20 ppm crystal oscillator
Power regulator	DC/DC regulator setup
Certifications	
USA (FCC)	FCC part 15 modular certification 47 CFR Part 15, Subpart C FCC ID: 2A094-MK08
Europe (CE)	EN 300 328 V2.2.2 3.2: Effective use of spectrum allocated EN 301 489-1 V2.2.3 3.1(b): Electromagnetic Compatibility EN 301 489-17 V3.2.4 EN 62368-1: 2014+A11:2017 3.1(a): Health and Safety of the user EN 62479: 2010
Canada (ISED)	Industry Canada RSS-247 and RSS-Gen certification IC: 26442-MK08
Japan (MIC)	Ministry of Internal Affairs and Communications (MIC) of Japan pursuant to the Radio Act of Japan MIC: 217-204214
Australia/New Zealand (RCM)	AS/NZS 4268: 2017, Radio equipment and systems-short range devices

2. Circuit Design

2.1 Block Diagram

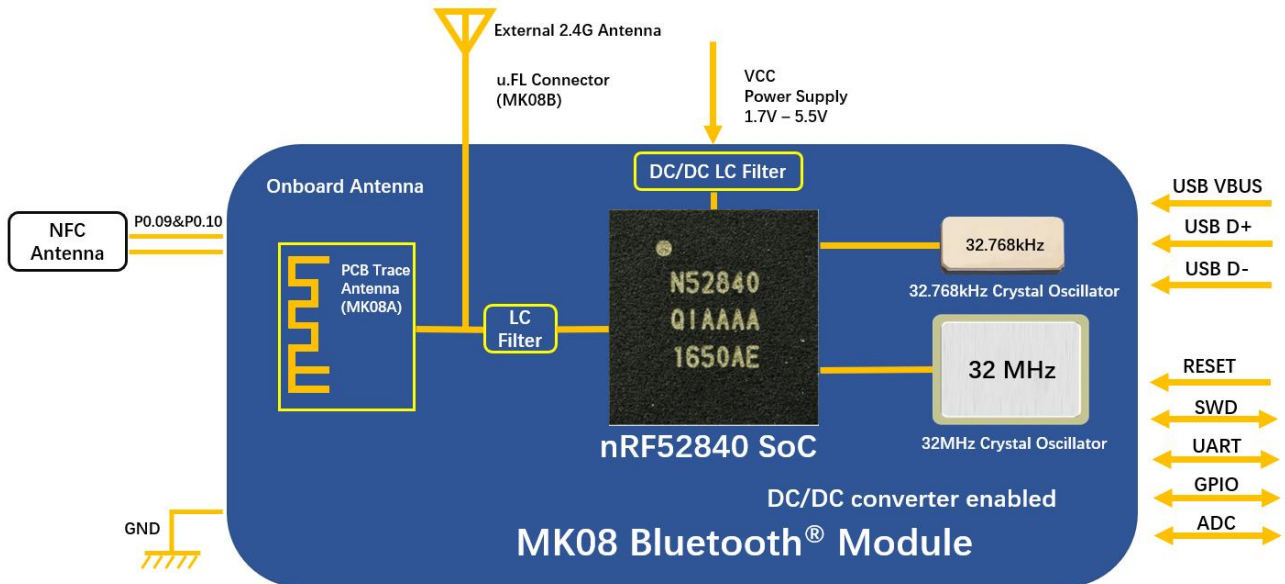

2.2 Reference Circuitry

2.2.1 Normal Voltage Mode

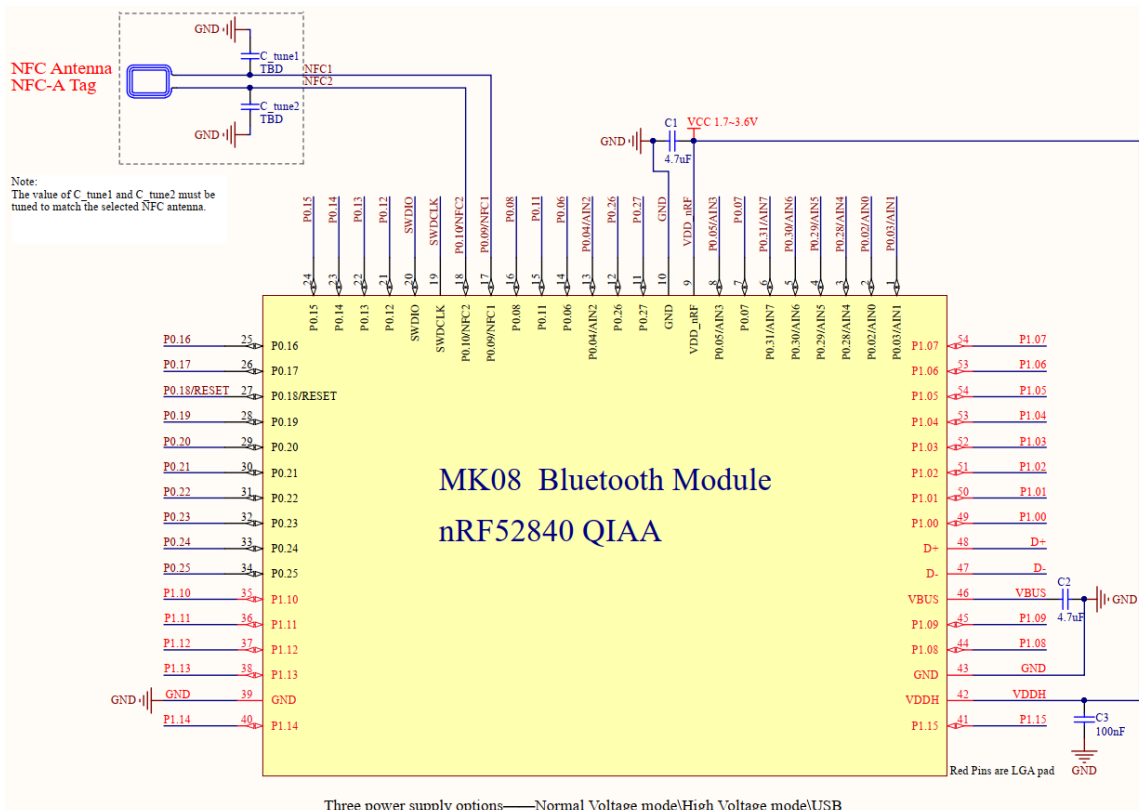

MK08 Bluetooth Module Datasheet

2.2.2 High Voltage Mode

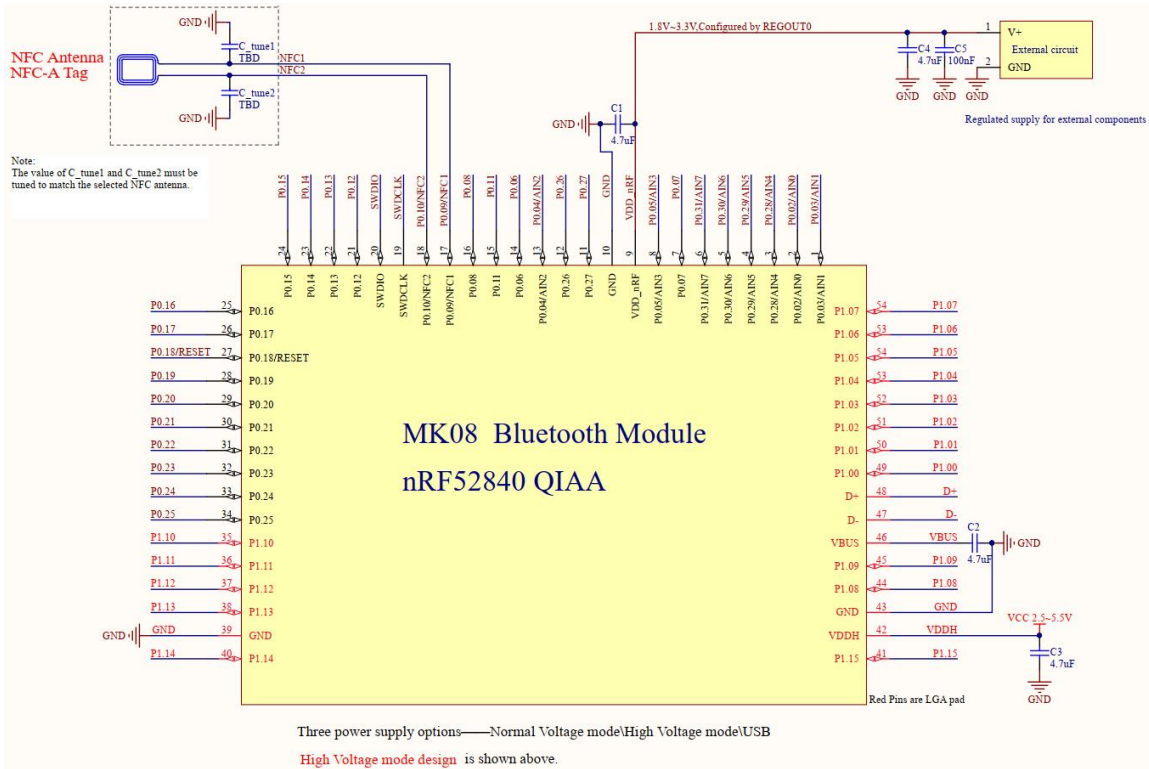

2.2.3 USB Voltage Mode

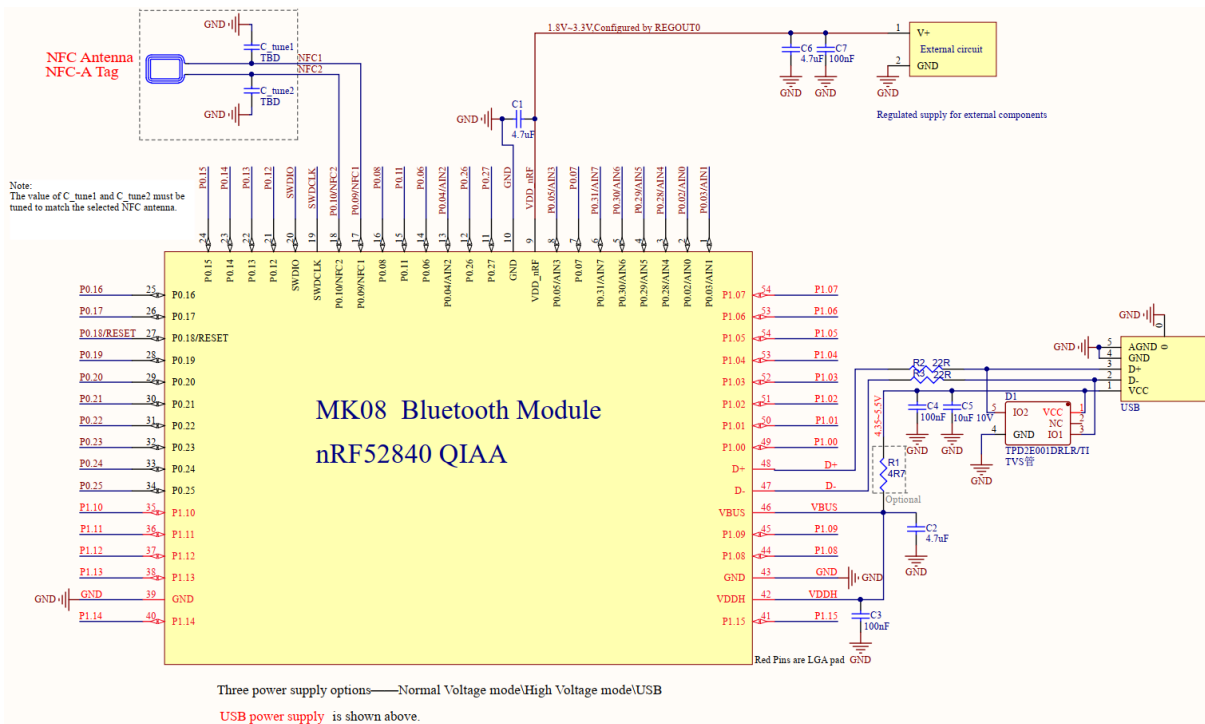

3. Mechanical specifications

3.1 Module Mechanical Dimensions

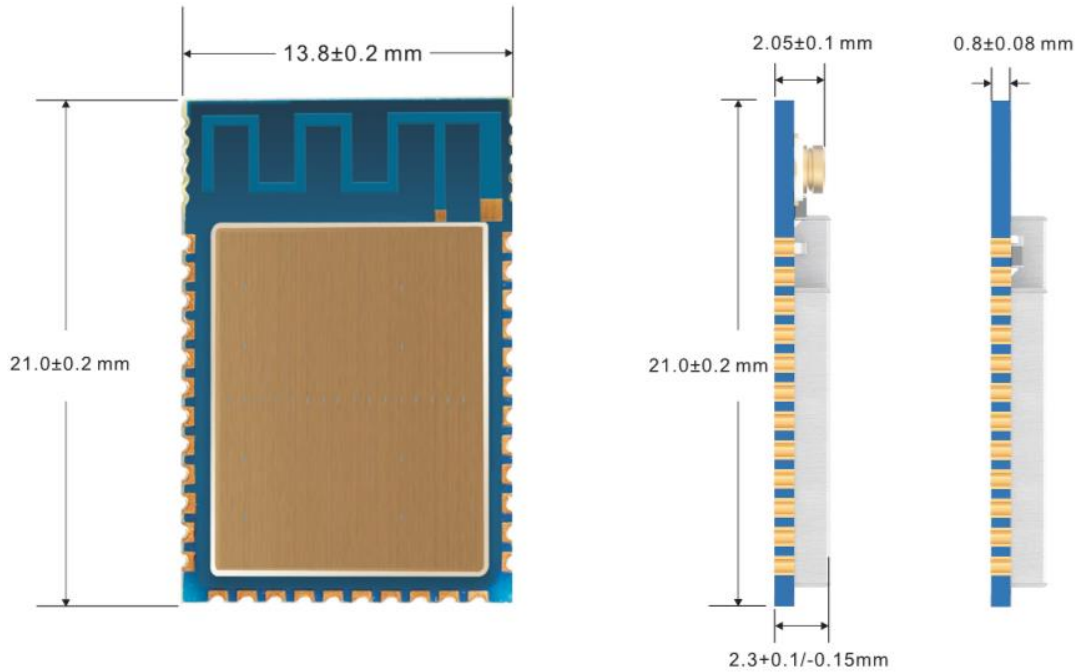

Symbol	Min.	Typ.	Max.
Length	-0.2mm	21mm	+0.2mm
Width	-0.2mm	13.8mm	+0.2mm
Height (PCB only)	-0.08mm	0.8mm	+0.08mm
Height (with shield)	-0.15mm	2.3mm	+0.1mm

3.2 Recommended PCB land pads

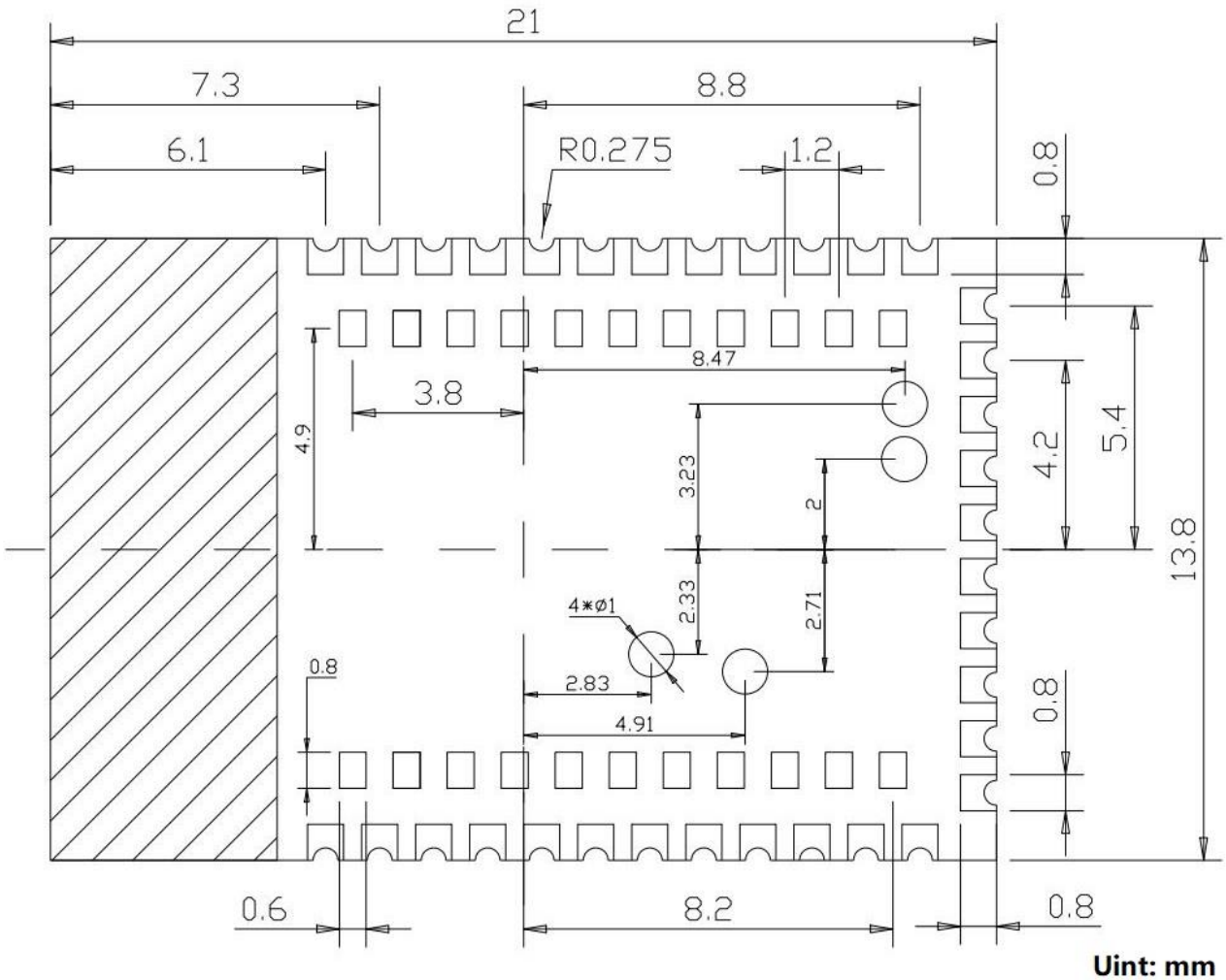

MK08 PCB land pads (TOP View)

Symbol	Typ.
Half-hole Pad (Bottom)	0.8mm x 0.8mm
LGA Square Pad	0.8mm x 0.6mm
LGA Round pad	1mm (diameter)
Diameter of Half-hole	0.55mm

4. Pin Assignment

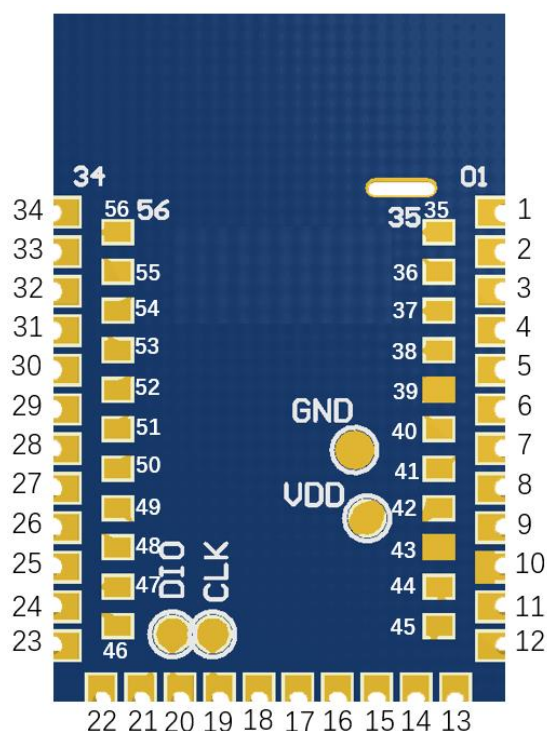

MK08 module pin diagram (Rear View)

Pin No.	Name	Type	Description
1	P0.03	Digital I/O	General purpose I/O
	AIN1	Analog input 1	SAADC/COMP/LPCOMP input
2	P0.02	Digital I/O	General purpose I/O
	AIN0	Analog input 0	SAADC/COMP/LPCOMP input
3	P0.28	Digital I/O	General purpose I/O
	AIN4	Analog input 4	SAADC/COMP/LPCOMP input
4	P0.29	Digital I/O	General purpose I/O
	AIN5	Analog input 5	SAADC/COMP/LPCOMP input
5	P0.30	Digital I/O	General purpose I/O
	AIN6	Analog input 6	SAADC/COMP/LPCOMP input
6	P0.31	Digital I/O	General purpose I/O
	AIN7	Analog input 7	SAADC/COMP/LPCOMP input
7	P0.07	Digital I/O	General purpose I/O
8	P0.05	Digital I/O	General purpose I/O
	AIN3	Analog input 3	SAADC/COMP/LPCOMP input
9	VDD	Power	Power Supply
10	GND	Power	Ground
11	P0.27	Digital I/O	General purpose I/O
12	P0.26	Digital I/O	General purpose I/O

MK08 Bluetooth Module

Datasheet

Pin No.	Name	Type	Description
13	P0.04	Digital I/O	General purpose I/O
	AIN2	Analog input 2	SAADC/COMP/LPCOMP input
14	P0.06	Digital I/O	General purpose I/O
15	P0.11	Digital I/O	General purpose I/O
	TRACEDATA[2]	Trace data	Trace buffer TRACEDATA
16	P0.08	Digital I/O	General purpose I/O
17	P0.09	Digital I/O	General purpose I/O
	NFC1	NFC input	NFC antenna connection
18	P0.10	Digital I/O	General purpose I/O
	NFC2	NFC input	NFC antenna connection
19	SWDCLK	Debug	Serial wire debug clock input for debug and programming
20	SWDIO	Debug	Serial wire debug I/O for debug and programming
21	P0.12	Digital I/O	General purpose I/O
	TRACEDATA[1]	Trace data	Trace buffer TRACEDATA
22	P0.13	Digital I/O	General purpose I/O
23	P0.14	Digital I/O	General purpose I/O
24	P0.15	Digital I/O	General purpose I/O
25	P0.16	Digital I/O	General purpose I/O
26	P0.17	Digital I/O	General purpose I/O
27	P0.18	Digital I/O	General purpose I/O
	nRESET		Configurable as pin RESET
28	P0.19	Digital I/O	General purpose I/O
29	P0.20	Digital I/O	General purpose I/O
30	P0.21	Digital I/O	General purpose I/O
31	P0.22	Digital I/O	General purpose I/O
32	P0.23	Digital I/O	General purpose I/O
33	P0.24	Digital I/O	General purpose I/O
34	P0.25	Digital I/O	General purpose I/O
35	P1.10	Digital I/O	General purpose I/O
36	P1.11	Digital I/O	General purpose I/O
37	P1.12	Digital I/O	General purpose I/O
38	P1.13	Digital I/O	General purpose I/O
39	GND	Power	Ground
40	P1.14	Digital I/O	General purpose I/O
41	P1.15	Digital I/O	General purpose I/O
42	VDDH	Power	High voltage power supply
43	GND	Power	Ground
44	P1.08	Digital I/O	General purpose I/O

MK08 Bluetooth Module

Datasheet

Pin No.	Name	Type	Description
45	P1.09	Digital I/O	General purpose I/O
	TRACEDATA[3]	Trace data	Trace buffer TRACEDATA
46	VBUS	Power	5 V input for USB 3.3 V regulator
47	D-	USB	USB D-
48	D+	USB	USB D+
49	P1.00	Digital I/O	General purpose I/O
	TRACEDATA[0]/ SWO	Trace data	Trace buffer TRACEDATA/ Serial wire output
50	P1.01	Digital I/O	General purpose I/O
51	P1.02	Digital I/O	General purpose I/O
52	P1.03	Digital I/O	General purpose I/O
53	P1.04	Digital I/O	General purpose I/O
54	P1.05	Digital I/O	General purpose I/O
55	P1.06	Digital I/O	General purpose I/O
56	P1.07	Digital I/O	General purpose I/O

Note: Please refer to [Nordic nRF52840 Product Specifications](#) for detailed descriptions and features supported about the Pin assignments.

5. Mounting Suggestion

You can refer to the following references for the mounting design of the module with on-board antenna (MK08A with PCB antenna).

For external antenna modules (MK08B needs to connect an external antenna to the u.FL connector), you need to refer to the external antenna design requirements.

Recommended module mounting example:

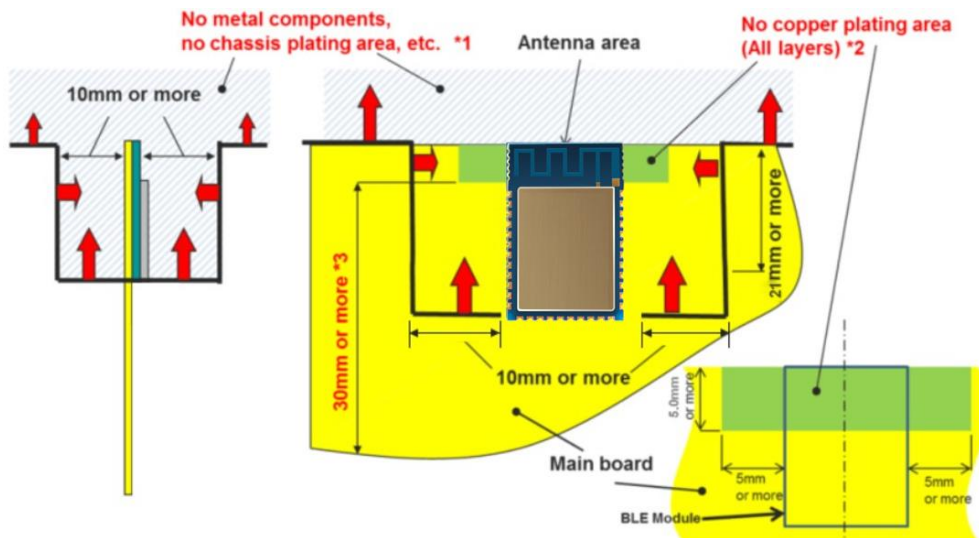

- Please do not place any metal components in blue shaded space (*1), such as signal line and metal chassis as possible except for main board while mounting the components in *1 space on the main board is allowed except for no copper plating area (*2).
- (*2) This area is routing prohibited area on the main board. Please do not place copper on any layer.
- (*3) Characteristics may deteriorate when GND pattern length is less than 30mm. It should be 30 mm or more as possible.
- For the best Bluetooth range performance, the antenna area of module shall extend 3 mm outside the edge of main board, or 3 mm outside the edge of a ground plane. Ground plane shall be at least 5 mm from the edge of the antenna area of module.
- All module GND pins MUST be connected to main board GND. Place GND vias close to module GND pads as possible. Unused PCB area on surface layer can be flooded with copper but place GND vias regularly to connect copper flood to inner GND plane. If GND flood copper underside the module then connect with GND vias to inner GND plane.
- Even when above mentioned condition is satisfied, communication performance may be significantly deteriorated depending on the structure of the product. Bluetooth range performance is degraded if a module is placed in the middle of the main board.
- For main board layout:
 - Avoid running any signal line below module whenever possible.
 - No ground plane below antenna.
 - If possible, cut-off the portion of main board below antenna.

MK08 Bluetooth Module

Datasheet

Other module mounting examples:

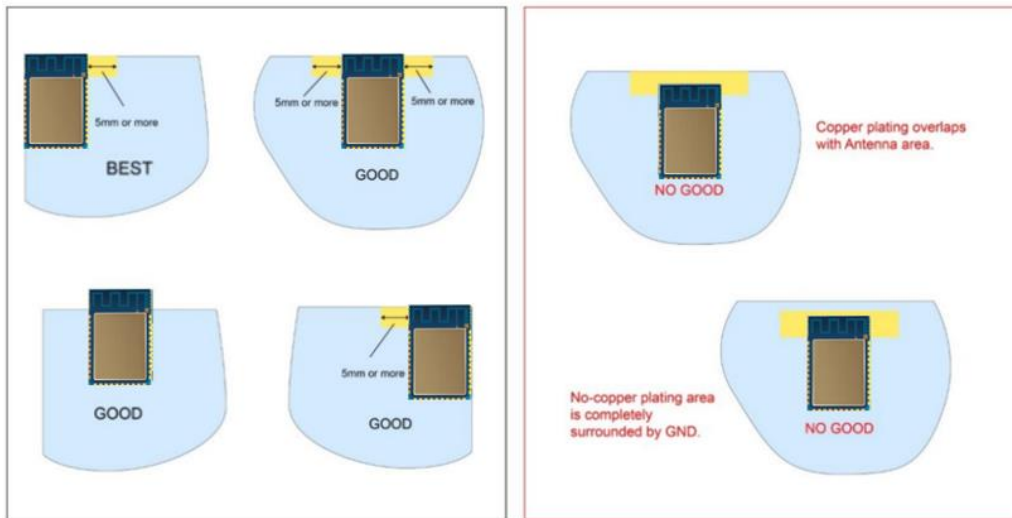

Placement of resin or plastic parts:

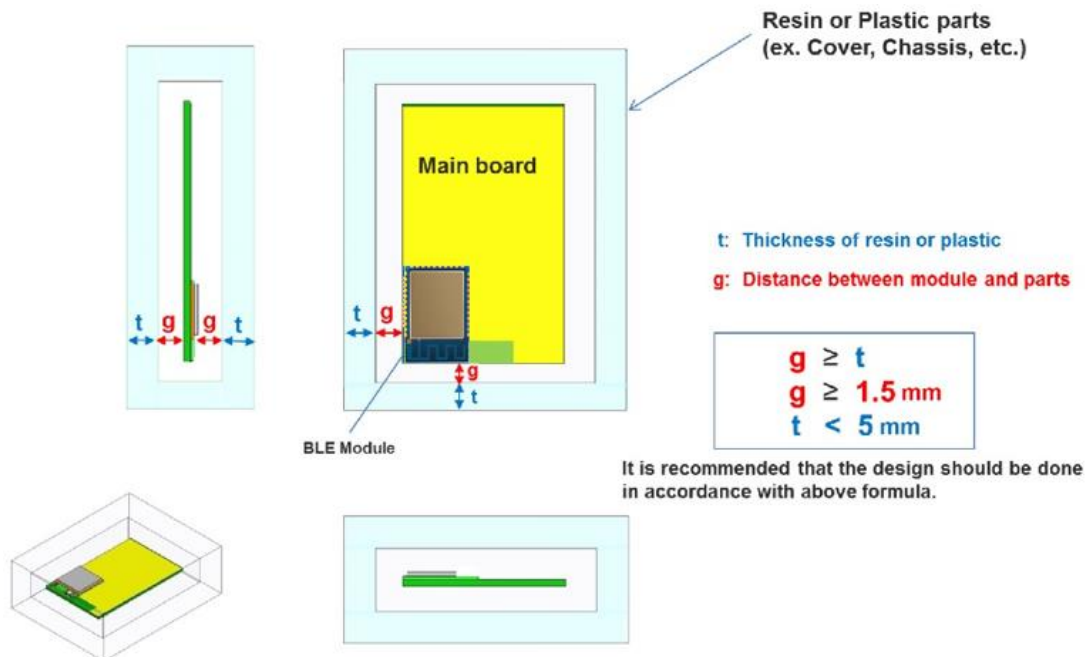

Please do not apply molding over the antenna area of BLE module.

Placement of metal parts

- Minimum safe distance for metal parts without seriously compromising the antenna (tuning) is 40 mm top/bottom and 30 mm left or right.
- Metal close to the module antenna (bottom, top, left, right, any direction) will have degradation on the antenna performance. The amount of that degradation is entirely system dependent, meaning you will need to perform some testing with your host application.
- Any metal closer than 20 mm will begin to significantly degrade performance (S11, gain, radiation efficiency).
- It is best that you test the range with a mock-up (or actual prototype) of the product to assess effects of enclosure height (and materials, whether metal or plastic).

6. Qualification and approvals

6.1 United States (FCC)

The MK08 has received Federal Communications Commission (FCC) CFR47 Telecommunications, Part 15 Subpart C “Intentional Radiators” modular approval in accordance with Part 15.247 Modular Transmitter approval. The modular approval allows the end user to integrate the module into a finished product without obtaining subsequent and separate FCC approvals for intentional radiation, provided no changes or modifications are made to the module circuitry. Changes or modifications could void the user’s authority to operate the equipment. The end user must comply with all of the instructions provided by the Grantee, which indicate installation and/or operating conditions necessary for compliance.

The finished product is required to comply with all applicable FCC equipment authorizations regulations, requirements and equipment functions not associated with the transmitter module portion. For example, compliance must be demonstrated to regulations for other transmitter components within the host product; to requirements for unintentional radiators (Part 15 Subpart B “Unintentional Radiators”), such as digital devices, computer peripherals, radio receivers, etc.; and to additional authorization requirements for the non-transmitter functions on the transmitter module (i.e., Verification, or Declaration of Conformity) (e.g., transmitter modules may also contain digital logic functions) as appropriate.

Note:

Modification to this product will void the users’ authority to operate this equipment.

The OEM is still responsible for verifying end product compliance with FCC Part 15, subpart B limits for unintentional radiators through an accredited test facility.

6.1.1 Labeling and user information requirements

The MK08 is assigned the FCC ID number: 2A094-MK08

If the FCC ID is not visible when the module is installed inside another device, then the outside of the finished product into which the module is installed must also display a label referring to the enclosed module. This exterior label can use the following or similar wording:

Contains FCC ID: 2A094-MK08

In addition to marking the product with the appropriate FCC ID, the end product user manual may also require specific information based on the digital device classification. Refer to the [FCC Rules, Title 47, Subchapter A, Part 15, Subpart B, Chapter §15.105](#) for specific wording of the notices.

6.1.2 RF exposure

All transmitters regulated by FCC must comply with RF exposure requirements. [KDB 447498 General RF Exposure Guidance](#) provides guidance in determining whether proposed or existing transmitting facilities, operations or devices comply with limits for human exposure to Radio Frequency (RF) fields adopted by the Federal Communications Commission (FCC).

This module is approved for installation into mobile and/or portable host platforms and must not be

co-located or operating in conjunction with any other antenna or transmitter except in accordance with FCC multi-transmitter guidelines. End users must be provided with transmitter operating conditions for satisfying RF Exposure compliance.

6.2 Canada (ISED)

The MK08 module is certified for use in Canada under Innovation, Science and Economic Development Canada (ISED) Radio Standards Specification (RSS) RSS-247 and RSSGen.

6.2.1 Labeling and user information requirements

The MK08 is assigned the ISED number: 26442-MK08

Labeling Requirements for the Host Device (from Section 3.2.1, RSS-Gen, Issue 3, December 2010): The host device shall be properly labeled to identify the module within the host device. The Industry Canada certification label of a module shall be clearly visible at all times when installed in the host device, otherwise the host device must be labeled to display the Industry Canada certification number of the module, preceded by the words “Contains transmitter module”, or the word “Contains”, or similar wording expressing the same meaning, as follows:

Contains transmitter module IC: 26442-MK08

User Manual Notice for License-Exempt Radio Apparatus (from Section 7.1.3 RSS-Gen, Issue 3, December 2010): User manuals for license-exempt radio apparatus shall contain the following or equivalent notice in a conspicuous location in the user manual or alternatively on the device or both:

This device complies with Industry Canada license exempt RSS standard(s). Operation is subject to the following two conditions: (1) this device may not cause interference, and (2) this device must accept any interference, including interference that may cause undesired operation of the device.

Le présent appareil est conforme aux CNR d'Industrie Canada applicables aux appareils radio exempts de licence. L'exploitation est autorisée aux deux conditions suivantes: (1) l'appareil ne doit pas produire de brouillage, et (2) l'utilisateur de l'appareil doit accepter tout brouillage radioélectrique subi, même si le brouillage est susceptible d'en compromettre le fonctionnement.

Transmitter Antenna (from Section 7.1.2 RSS-Gen, Issue 3, December 2010): User manuals for transmitters shall display the following notice in a conspicuous location:

Under Industry Canada regulations, this radio transmitter may only operate using an antenna of a type and maximum (or lesser) gain approved for the transmitter by Industry Canada. To reduce potential radio interference to other users, the antenna type and its gain should be so chosen that the equivalent isotropically radiated power (e.i.r.p.) is not more than that necessary for successful communication.

Conformément à la réglementation d'Industrie Canada, le présent émetteur radio peut fonctionner avec une antenne d'un type et d'un gain maximal (ou inférieur) approuvé pour l'émetteur par Industrie Canada. Dans le but de réduire les risques de brouillage radioélectrique à l'intention des autres utilisateurs, il faut choisir le type d'antenne et son gain de sorte que la puissance isotrope rayonnée équivalente (p.i.r.e.) ne dépasse pas l'intensité nécessaire à l'établissement d'une communication satisfaisante.

6.2.2 RF exposure

All transmitters regulated by IC must comply with RF exposure requirements listed in RSS-102 - Radio Frequency (RF) Exposure Compliance of Radiocommunication Apparatus (All Frequency Bands). This module is approved for installation into mobile and/or portable host platforms and must not be co-located or operating in conjunction with any other antenna or transmitter except in accordance with Industry Canada's multi-transmitter guidelines. End users must be provided with transmitter operating conditions for satisfying RF Exposure compliance.

6.3 European Union regulatory compliance

Information about regulatory compliance of the European Union for the MK08 module is available in the MK08 Declaration of Conformity.

6.3.1 Radio Equipment Directive (RED) 2014/53/EU

The MK08 module complies with the essential requirements and other relevant provisions of Radio Equipment Directive (RED) 2014/53/EU.

6.3.2 Labeling and user information requirements

The label on the final products which contain the MK08 module must follow CE marking requirements. The "R&TTE Compliance Association Technical Guidance Note 01" provides guidance on final product CE marking.

6.4 Japan (MIC)

The MK08 module has received type certification and is labeled with its own technical conformity mark and certification number as required to conform to the technical standards regulated by the Ministry of Internal Affairs and Communications (MIC) of Japan pursuant to the Radio Act of Japan. Integration of this module into a final end product does not require additional radio certification provided installation instructions are followed and no modifications of the module are allowed.

Additional testing may be required:

- If the host product is subject to electrical appliance safety (for example, powered from an AC mains), the host product may require Product Safety Electrical Appliance and Material (PSE) testing. The integrator should contact their conformance laboratory to determine if this testing is required.
- There is a voluntary Electromagnetic Compatibility (EMC) test for the host product administered by VCCI: http://www.vcci.jp/vcci_e/index.html

The label on the end product which contains a MK08 module must follow the MIC marking requirements. Labeling requirements for Japan available at the Ministry of Internal Affairs and Communications (MIC) website: <http://www.tele.soumu.go.jp/e/index.htm>.

MK08 Bluetooth Module

Datasheet

The MK08 module is labeled with its assigned technical conformity mark and certification number. The end product in which this module is being used must have an external label referring to the type certified module inside:

Contains transmitter module with certificate number: 217-204214



6.5 Australia / New Zealand (RCM)

The MK08 has been tested to comply with the AS/NZS 4268:2017, Radio equipment and systems - Short range devices - Limits and methods of measurement. The report may be obtained from your local FAE, and may be used as evidence in obtaining permission to use the Regulatory Compliance Mark (RCM).

Information on registration as a Responsible Party, license and labeling requirements may be found at the following websites:

Australia: <http://www.acma.gov.au/theACMA/radiocommunications-short-range-devices-standard-2004>

New Zealand: <https://www.rsm.govt.nz/business-individuals/compliance-information-for-licence-holders/licence-compliance-requirements/>

Only Australian-based and New Zealand-based companies who are registered may be granted permission to use the RCM. An Australian-based or New Zealand-based agent or importer may also register as a Responsible Party to use the RCM on behalf of a company not in Australia or New Zealand.

7 Cautions

7.1 Reflow Soldering

Reflow soldering is a vitally important step in the SMT process. The temperature curve associated with the reflow is an essential parameter to control to ensure the correct connection of parts. The parameters of certain components will also directly impact the temperature curve selected for this step in the process.

Temperature-Time Profile for Reflow Soldering:

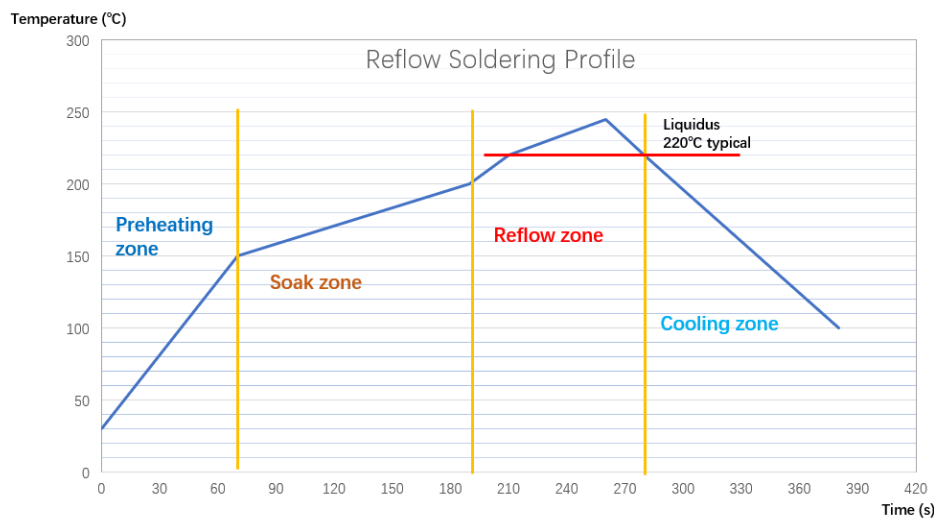

- The standard reflow profile has four zones: ①preheat, ②soak, ③reflow, ④cooling. The profile describes the ideal temperature curve of the top layer of the PCB.
- During reflow, modules should not be above 260°C and not for more than 30 seconds.

Specification	Value
Temperature Increase Rate	<2.5°C / s
Temperature Decrease Rate	Free air cooling
Preheat Temperature	0-150°C
Preheat Period (Typical)	40-90s
Soak Temp Increase Rate	0.4-1°C / s
Soak Temperature	150-200°C
Soak Period	60-120s
Liquidus Temperature (SAC305)	220°C
Time Above Liquidous	45-90s
Reflow Temperature	230-250°C
Absolute Peak Temperature	260°C

MK08 Bluetooth Module

Datasheet

Example of MOKO SMT reflow soldering:

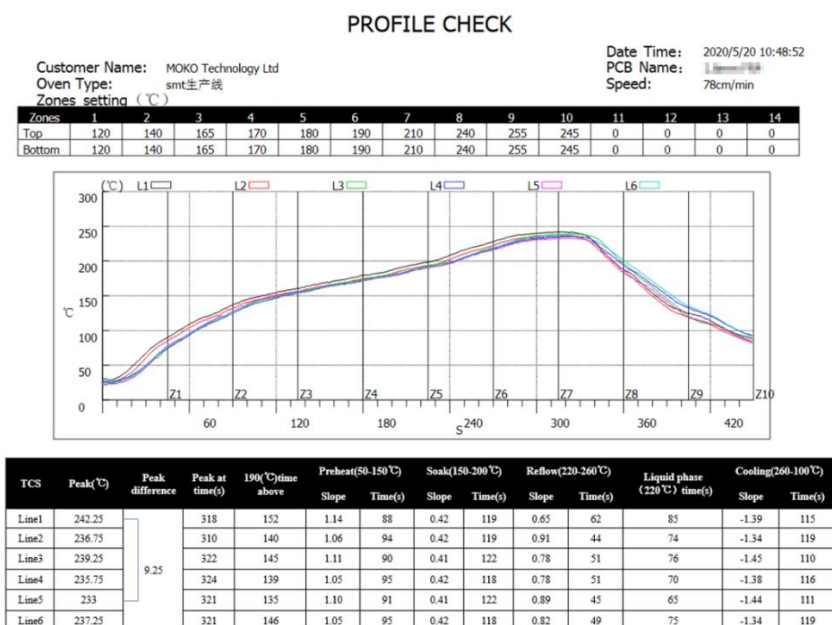

Note: The module is LGA package. Please be careful of the amount of solder paste. The module may be lifted due to excess solder.

7.2 Usage Condition Notes

- Follow the conditions written in this specification, especially the recommended condition ratings about the power supply applied to this product.
- The supply voltage has to be free of AC ripple voltage (for example from a battery or a low noise regulator output). For noisy supply voltages, provide a decoupling circuit (for example a ferrite in series connection and a bypass capacitor to ground of at least 47uF directly at the module).
- Take measures to protect the unit against static electricity. If pulses or other transient loads (a large load applied in a short time) are applied to the products, check and evaluate their operation before assembly on the final products.
- The supply voltage should not be exceedingly high or reversed. It should not carry noise and/or spikes.
- This product away from other high frequency circuits.
- Keep this product away from heat. Heat is the major cause of decreasing the life of these products.
- Avoid assembly and use of the target equipment in conditions where the products' temperature may exceed the maximum tolerance.
- This product should not be mechanically stressed when installed.
- Do not use dropped products.
- Do not touch, damage or soil the pins.
- Pressing on parts of the metal shield or fastening objects to the metal shield will cause damage.

7.3 Storage Notes

- The module should not be stressed mechanically during storage.
- Do not store these products in the following conditions or the performance characteristics of the product, such as RF performance will be adversely affected:
 - Storage in salty air or in an environment with a high concentration of corrosive gas.
 - Storage in direct sunlight
 - Storage in an environment where the temperature may be outside the range specified.
 - Storage of the products for more than one year after the date of delivery storage period.
- Keep this product away from water, poisonous gas and corrosive gas.
- This product should not be stressed or shocked when transported.

Revision History

Revision	Description of changes	Approved	Revision Date
V1.0	Initial Release	Victor	2020.11.25
V1.2	Added Section 6 Qualification and approvals	Victor	2020.12.24

MK08 Bluetooth Module

Datasheet

The contents of this datasheet are subject to change without prior notice for further improvement. MOKO team reserves all the rights for the final explanation.

Please contact MOKO sales team or visit <https://www.mokoblue.com> to get more related information if needed.

MOKO TECHNOLOGY LTD.

 4F,Buidling2, Guanghui Technology Park,
MinQing Rd, Longhua, Shenzhen, Guangdong, China

 Tel:86-755-23573370-829

 Support_BLE@mokotechnology.com

 <https://www.mokoblue.com>

